

VP25

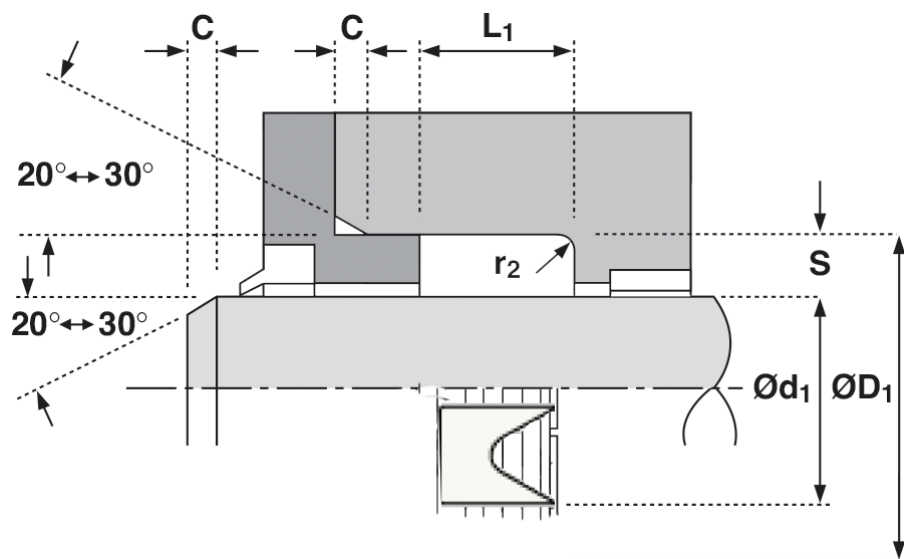

Technical Details

Metric

Inch

Operating conditions		
Maximum speed	0.5 m/sec	1.5 ft/sec
Temperature range	-30°C + 100°C	-22°F + 212°F
Maximum pressure	400 Bar	6000 p.s.i

Maximum extrusion gap

Pressure bar	100	175	250	400
Maximum gap mm	0.45	0.4	0.3	0.2
Pressure p.s.i	1500	2250	3500	6000
Maximum gap in	0.018	0.015	0.010	0.007

Surface roughness

	µmRa	µmRt	µinCLA	µinRMS
Dynamic sealing surface Rod Ød ₁	0.1 - 0.4	4 max	4 - 16	5 - 18
Static sealing face Rod ØD ₁	1.6 max	10 max	63 max	70 max
Dynamic sealing surface Piston Ød ₁	0.1 - 0.4	4 max	4 - 16	5 - 18
Static sealing face Piston ØD ₁	1.6 max	10 max	63 max	70 max
Static housing faces L ₁	3.2 max	16 max	125 max	140 max

Chamfers & Radii

Groove section S mm	5.0	7.5	10.0	12.5	15.0
Min chamfer C mm	3.0	5.0	6.5	7.0	7.5
Max fillet rad r ₁ mm	0.5	0.8	0.8	0.8	0.8
Groove section S in	0.187	0.250	0.312	0.375	0.500
Min chamfer C in	0.093	0.125	0.156	0.187	0.250
Max fillet rad r ₁ in	0.020	0.031	0.031	0.031	0.031

Tolerances

	Ød ₁	ØD ₁	L ₁ mm	L ₁ in
Rod	f9	Js11	+0.75 - 0.0	+0.030 - 0
Piston	js11	H9	+0.75 - 0.0	+0.030 - 0

DESIGN

VP25 is a bottom adaptor. It is used to support the base of the vee packer from moving out of place. It also keeps the vee packer seal set in its central position when it is under load tension.